



Type 8693 can be combined with...



Type 2301

Globe control valve



Type 2300

Angle-seat control valve



Type 2103

Diaphragm control valve

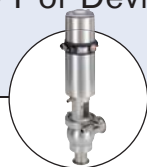

Hygienic process control valves

Digital electropneumatic process controller for the integrated mounting on process control valves

- Compact, robust stainless Steel design
- Easy start-up by Tune function for position and process controller
- Contact-free position sensor
- Integrated control air routing with spring chamber aeration
- Profibus DPV1 or DeviceNet communication (option)

The compact process controller Type 8693 is optimized for integrated mounting on the pneumatic actuators in the process valve series Type 23xx/2103 and is specially designed for the requirements of a hygienic process environment. The actual value of the process factor is directly supplied to the device as 4-20 mA, PT100 or a frequency signal. The process controller calculates the setpoint for the subordinated positioner through the variance comparison. Due to the analogue feedback all analogue values on the controlling level can be transferred. With integrated diagnostic functions operation conditions of the control valve can be monitored. Through status signals, valve diagnostic messages are transmitted according to NAMUR NE107 and recorded as history entries. The parameterization of process controller and positioner can be carried out automatically. The easy handling and the selection of additional software functions are done either on a big graphic display with backlight and keypad or over a PC interface. The positioner registers the valve position without deterioration through a contact-free, analog position sensor. The control of single or double-acting actuators is done without internal air consumption. Communication interfaces such as Profibus DPV1 or DeviceNet and analogue as well as binary feedback can also be chosen.

¹⁾ The supply pressure has to be 0,5 - 1 bar above the minimum required pilot pressure for the valve actuator.

Technical data		
Material	Body	PPS, stainless steel
	Cover	PC
	Sealing	EPDM
Power supply	24 V DC +/- 10% UL: NEC Class 2	
Ripple	10%, no technical direct current!	
Setpoint setting	0/4 to 20 mA and 0 to 5/10 V	
Output resistance	0/4 to 20 mA:	180 Ω
	0 to 5/10 V:	19 k Ω
Sensor input	4 to 20 mA (180 Ω input resistance)	
	frequency 0 to 1000 Hz (17 kΩ input resistance)	
	PT100 -20 to +220 °C (resolution < 0.1 °C)	
Control medium	Dust concentration	neutral gases, air, quality classes acc. to ISO 8573-1
	Particle density	Class 7 (<40 µm particle size)
	Pressure condensation point	Class 5 (<10 mg/m ³)
	Oil concentration	Class 3 (<-20 °C) Class X (<25 mg/m ³)
Ambient temperature	-10 to +55 °C	
Pilot air ports	Threaded ports G 1/8 stainless steel or push-in connector (tube Ø 6 mm / 1/4")	
Supply pressure	Low air flow rate	0 to 7 bar ¹⁾
	High air flow rate	3 to 7 bar
Air input filter	Exchangeable (mesh aperture~0.1 mm)	
Actuator system	Low air flow rate:	ø Actuator 70 / 90 mm
	High air flow rate:	ø Actuator 130 mm
Position detection module	Contact-free, wear-free	
Stroke range valve spindle	3 to 45 mm	
Installation	as required, preferably with actuator in upright position	
Protection type	IP65/IP67 acc. to EN 60529, Type 4X acc. to NEMA 250 standard	
Power consumption	< 5 W	
Electrical connection	Multipole connection	M12, 8-pins or 4-pins
	Cable gland	2xM16x1,5 (cable-ø 10 mm) on terminal screws (1,5 mm ²)
Bus communication	Profibus DPV1, DeviceNet	
Approvals	ATEX II cat. 3G/D	
	cULus Cert. No. 238179	
Ignition protection	II 3D Ex tc IIIC T135 °C Dc	
	II 3G Ex nA IIC T4 Gc	
Protection class	3 acc. to DIN EN 61140	
Conformity	EMC directive 2014/30/EU	

Ordering information for ELEMENT TopControl control valve systems

A TopControl control valve system consists of a **process controller Type 8693** and an **ELEMENT control valve Type 23xx/2103**.

The following information is necessary for the selection of a complete control valve:

- **Item no.** of the desired TopControl process controller **Type 8693** (see ordering chart on p. 3)
- **Item no.** of the selected control valve **Type 23xx/2103** (see separate datasheets, e.g. 2300, 2301 or 2103)

You order two components and receive a complete assembled and certified valve.

When you click on the orange box "More info." below, you will come to our website for the resp. product where you can download the datasheet.

Example of variations of control valve systems

Positioner Type 8693



Pneumatic process control valve



More info.

Globe control valve
Type 2301



More info.

Angle-seat control valve
Type 2300



More info.

Diaphragm control valve
Type 2103



Control valve system



ELEMENT control valve system
Type 8802-GD-J
2301 + 8693



ELEMENT control valve system
Type 8802-YG-J
2300 + 8693



ELEMENT control valve system
Type 8802-DF-J
2103 + 8693



More info.

Customised attachment to third party actuators*

*please see datasheet 8681/ ELEMENT installation kits to 3rd party process valves or contact your sales office for related drawings or individual engineering support

Ordering chart Type 8693 (other versions on request)

Control function Pilot valve system	Communi- cation	Electrical connection	Analogue feedback 0/4-20 mA	Analogue feedback 0/4-20 mA + 2 binary outputs	Diagnostic function*	Binary input	Pilot air ports threaded ports	Item no.		
Actuator series ELEMENT Type 23xx, size Ø 70/90 mm								Standard	ATEX II cat. 3G/D	
Low air capacity single-acting		Cable gland				yes	G 1/8	227 352	265 086	
				yes	yes	yes	G 1/8	227 804	265 087	
						yes	yes	yes	G 1/8	242 019
		M12 multipole						G 1/8	265 090	265 089
			Profibus DPV1	via Bus				G 1/8	311 800	311 801
			DeviceNet	via Bus				G 1/8	265 092	265 094
low air capacity double-acting		Cable gland				yes	G 1/8	227 339	265 096	
				yes	yes	yes	G 1/8	265 098	265 097	
						yes	yes	yes	G 1/8	265 099
		M12 multipole						G 1/8	265 100	265 102
			Profibus DPV1	via Bus				G 1/8	311 802	311 803
			DeviceNet	via Bus				G 1/8	265 104	265 106
Actuators series ELEMENT Type 23xx, size Ø 130 mm										
High air capacity single-acting		Cable gland				yes	G 1/8	227 375	265 107	
				yes	yes	yes	G 1/8	244 380	265 108	
						yes	yes	yes	G 1/8	265 109
		M12 multipole						G 1/8	265 110	265 112
			Profibus DPV1	via Bus				G 1/8	311 804	311 805
			DeviceNet	via Bus				G 1/8	265 113	265 115

*see additional software functions Parametrisable diagnostic functions / binary outputs on page 9

Note: All non-ATEX versions are UL approved.

i Further versions on request

> Additional
push-in pilot air ports (tube Ø 6 mm / 1/4")

Ordering chart adapter kit (has to be ordered separately)

Descrip- tion	Actuator size	Control function	Item no.
Adapter kit ELEMENT Type 23xx/2103	Ø 70 / 90 / 130 mm	universal	679 917

For installation kits to 3rd party process valves please see datasheet installation kits for hygienic process valves or contact your sales office for related drawings or individual engineering support

Ordering chart accessories

Descrip- tion	Item no.
M12 socket 8-pin with 5 m cable for input and output signals	919 267
M12 socket 4-pin with 5 m cable for power supply	918 038
M8 socket 4-pin with 5 m cable for process actual value from sensor	264 602
M8 connector, 4-pins, Initiator	917 131
Silencer G 1/8	780 779
Silencer, push-in connector	902 662
Sensor puck (spare part)	682 240
USB interface for serial communication	227 093

Materials

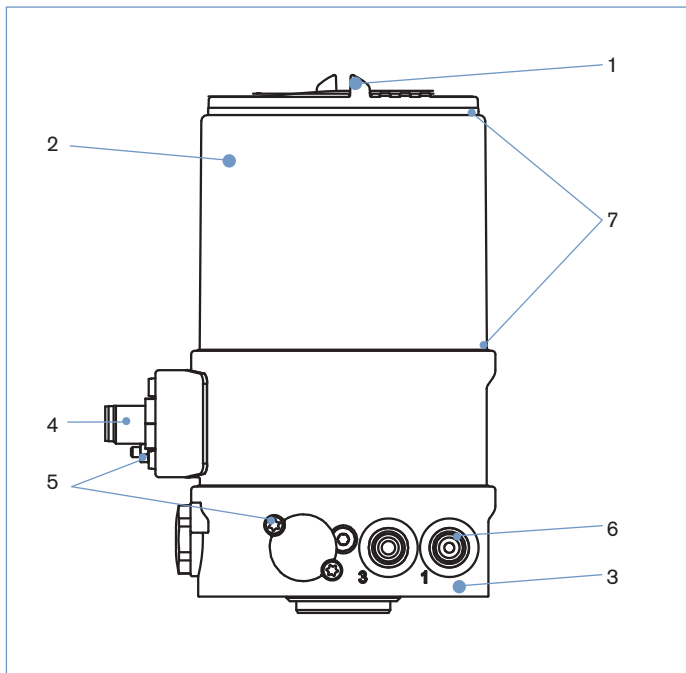

- | | |
|-----------------------------|---------------------|
| 1 Cover | PC |
| 2 Body casing | Stainless steel |
| 3 BASIC body | PPS |
| 4 Plug M12 | Stainless steel |
| 5 Screws | Stainless steel |
| 6 Push-in connector | POM/stainless steel |
| Threaded ports G 1/8 | Stainless steel |
| 7 Sealing | EPDM |

Dimensions [mm]

Version connection Multipole

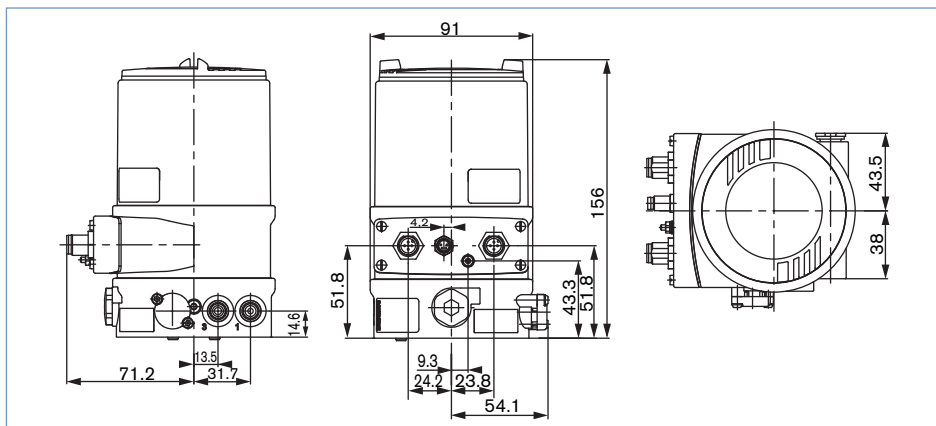

Version connection cable glands

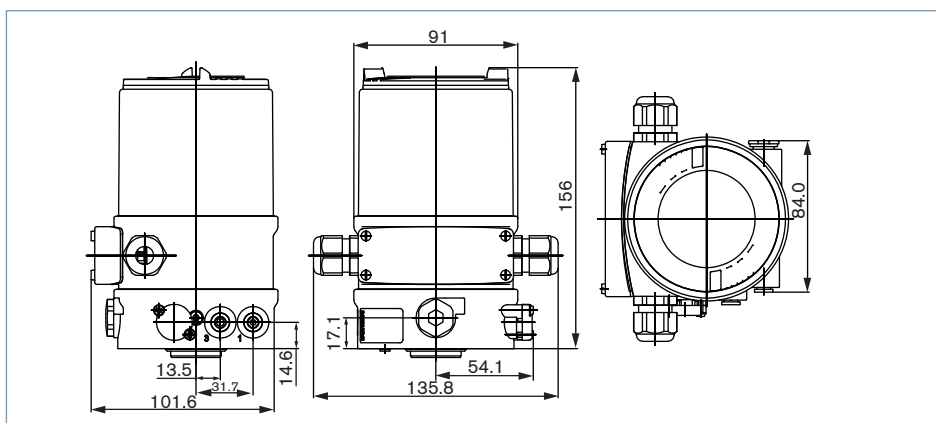

Dimensions [mm]

Mounting on process valve ELEMENT Types 23xx

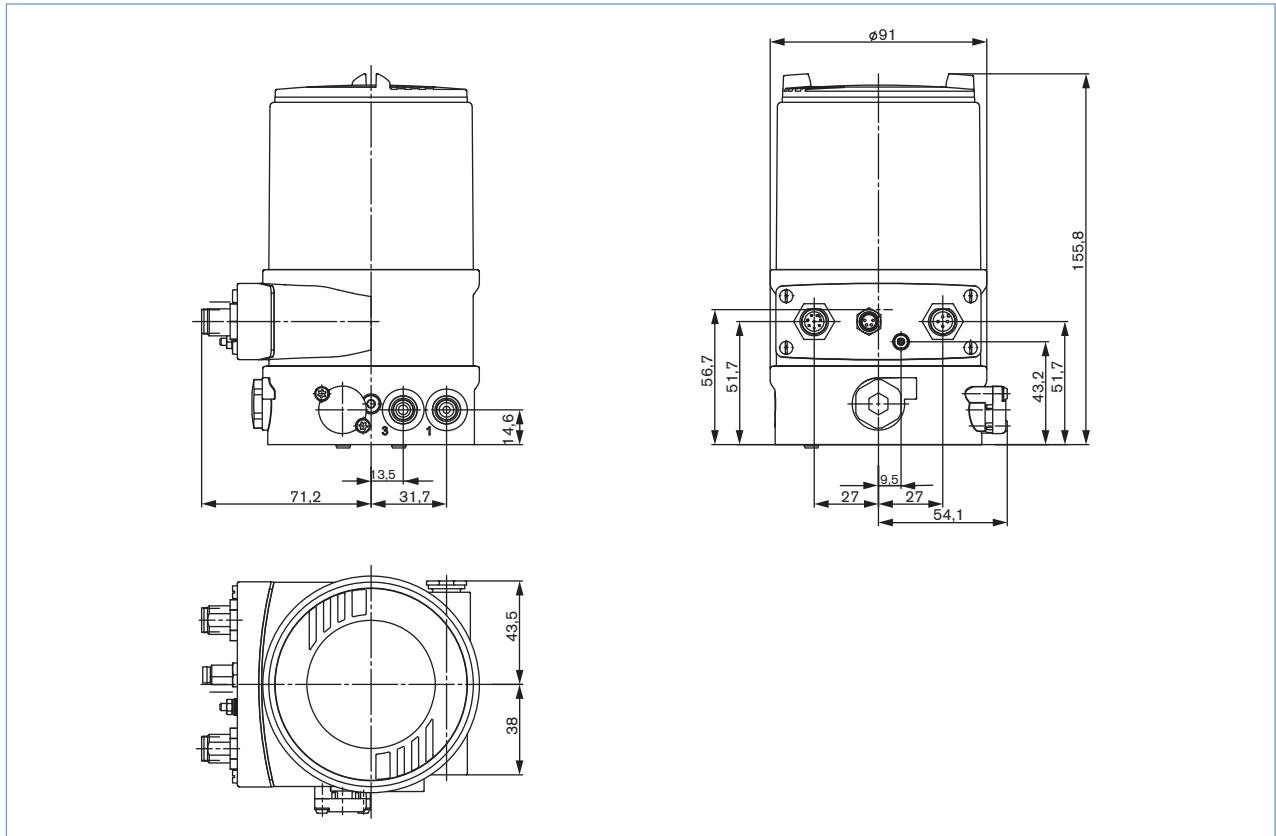

Connection options

Connection Multipole

Circular connector M12 - 8-pins (setpoint)

Pin	Configuration
8	Setpoint + (0/4 - 20 mA / 0 - 5/10 V)
7	Setpoint GND

Circular connector M8 - 4-pins (actual process value)*

Pin	Configuration
6	Analogue feedback +
5	Analogue feedback GND
4	Binary output 1
3	Binary output 2
2	Binary output GND
1	Binary input +

* with the option analogue feedback or binary output

Circular connector M12 - 4-pins (supply)

Pin	Configuration
1	Operating voltages + 24 V DC
3	Operating voltage GND

Circular connector M12 - 8-pins (in / output signal)*

Pin	Configuration
6	Analogue feedback +
5	Analogue feedback GND
4	Binary output 1
3	Binary output 2
2	Binary output GND
1	Binary input +

* with the option analogue feedback or binary output

Circular connector M8 - 4-pins (actual process value)

Input type*	Pin	Configuration	Switch
4-20 mA - internally supplied	1	+24 V transmitter supply	Switch on left
	2	Output from transmitter	
	3	GND	
	4	Bridge after GND	
4-20 mA - externally supplied	1	not assigned	Switch on right
	2	Actual value +	
	3	not assigned	
	4	Actual value -	
Frequency - internally supplied	1	+24 V sensor supply	Switch on left
	2	Clock input +	
	3	Clock input - (GND)	
	4	not assigned	
Frequency - externally supplied	1	not assigned	Switch on right
	2	Clock input +	
	3	Clock input -	
	4	not assigned	
Pt 100 (see notes to the right)	1	not assigned	Switch on right
	2	Process actual 1 (current feed)	
	3	Process actual 2 (GND)	
	4	Process actual 3 (compensation)	

* with the option analogue feedback or binary output

IMPORTANT!

For reasons of wire compensation connect the Pt 100 sensor via 3 wires. Always bridge Pin 3 and Pin 4 on the sensor.

Connection options, continued

Connection cable glands

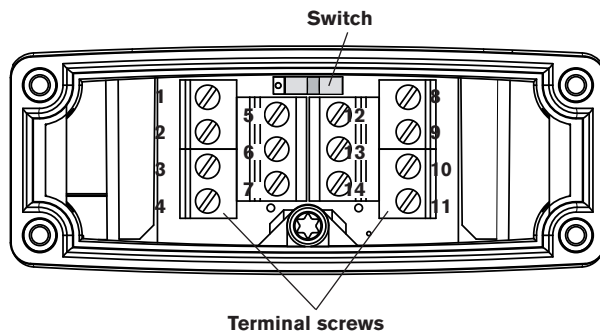

Clamp	Configuration
11	Setpoint + (0/4 - 20 mA / 0 - 5/10 V)
10	Setpoint GND
14	Operating voltages + 24 V DC
13	Operating voltage GND
12	Binary input +
13	Binary input GND
9*	Analogue position feedback +
8*	Analogue position feedback GND
5*	Binary output 1
6*	Binary output GND
7*	Binary output 2

Actual process value

Input type*	Pin	Configuration	Switch
4-20 mA - internally supplied	1	+24 V transmitter supply	 Switch on left
	2	Output from transmitter	
	3	Bridge after GND	
	4	GND	
4-20 mA - externally supplied	1	not assigned	 Switch on right
	2	Process actual +	
	3	Process actual -	
	4	not assigned	
Frequency - internally supplied	1	+24 V sensor supply	 Switch on left
	2	Clock input +	
	3	not assigned	
	4	Clock input - (GND)	
Frequency - externally supplied	1	not assigned	 Switch on right
	2	Clock input +	
	3	not assigned	
	4	Clock input -	
Pt 100 (see note to the right)	1	not assigned	 Switch on right
	2	Process actual 1 (current feed)	
	3	Process actual 2 (compensation)	
	4	Process actual 3 (GND)	

IMPORTANT!

For reasons of wire compensation connect the Pt 100 sensor via 3 wires. Always bridge Pin 3 and Pin 4 on the sensor.

* with the option analogue feedback or binary output

Signal flow diagram

Process control circuit

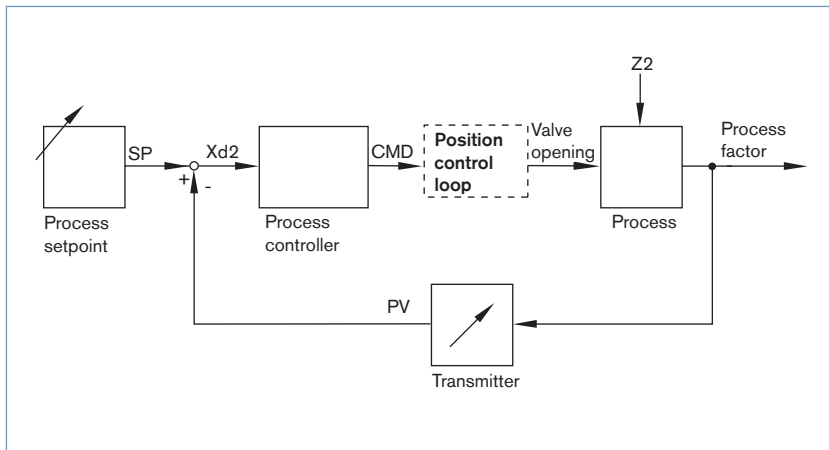

Position control loop

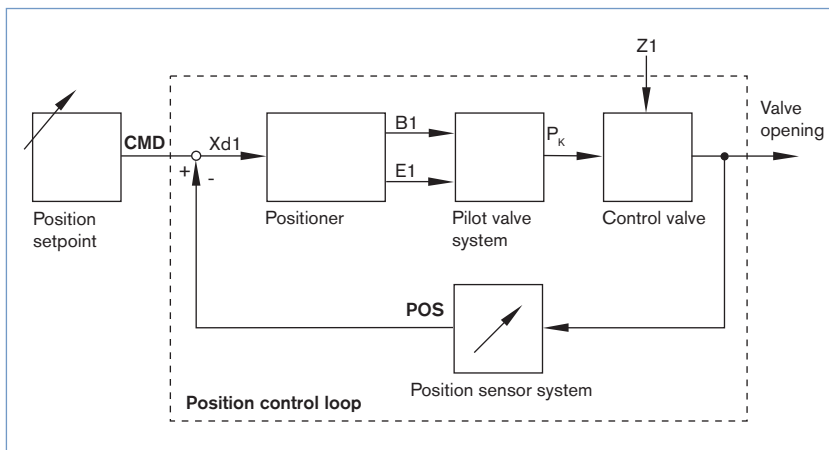

Additional software functions of the TopControl Type 8693

- Automatic start of the control valve systems
- Automatic parameterization of the process control circuit
- Automatic or manual characteristic curves selection
- Setting of the seal and the maximum stroke threshold respectively
- Parameterization of the positioner
- Manual parameterization of the process controller
- Limitation of the stroke range
- Limitation of the manipulating speed
- Setting of the moving direction
- Configuration of the binary input
- Signal range splitting on several controllers
- Configuration of an analogue or double binary outputs
- Signal fault detection
- Safety position
- Code protection
- Contrast inversion of the display
- Language selection

- Parametrisable diagnostic functions* / Binary outputs (option)

- Operating-hours counter
- Path accumulator
- Position monitoring
- Process actual value monitoring
- Monitoring of the mechanical end positions in the armature
- Graphical display of the dwell time density and movement range
- Direction reversal counter
- Temperature monitoring

* You will find a more detailed description for every diagnostic function in the operating manual of Type 8792, page 148 - 167

Schematic diagram of the Type 8693

Without fieldbus interface

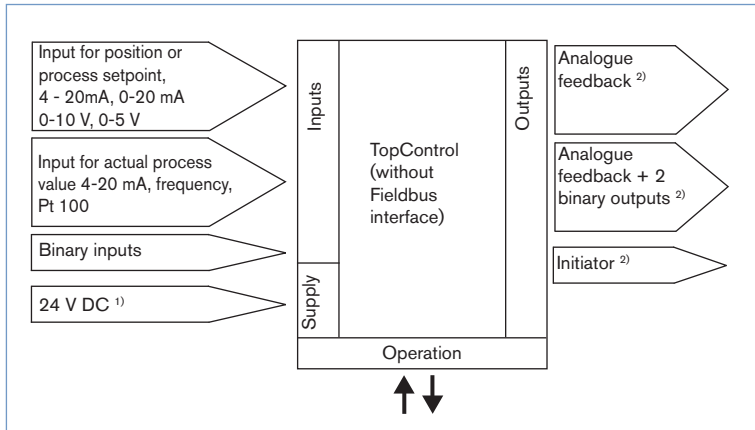

With Profibus DP / DeviceNet

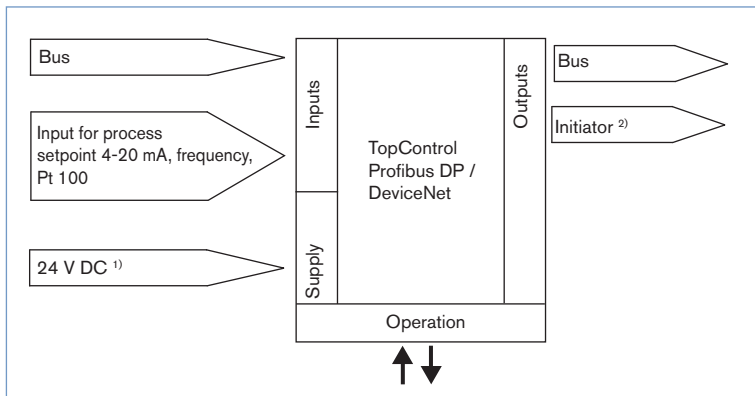

¹⁾ The operating voltage is supplied with a 3-wire unit independent from the setpoint signal.

²⁾ Alternative options

To find your nearest Bürkert facility, click on the orange box → www.burkert.com